



**WELCOMES YOU TO SUGARING WITH THE *DIY SEEDLING MAPLE SYRUP
EVAPORATOR KIT – WITHOUT BARREL***

The Vermont Evaporator Company's *DIY Seedling Maple Syrup Evaporator Kit – without Barrel* is designed for the backyard sugaring enthusiast who is willing to construct a firebox from their own 55-gallon barrel.

When you are finished, you will have a portable, backyard maple sap evaporator that features the *Seedling Evaporator Pan*; an 18-gauge, food-grade stainless steel pan with lead-free welds and a lead-free, brass pour-off valve. Although your pan is of a simple design, it does have some advanced features. Your pan is a continuous-flow pan, which allows sap to flow around the dividers. This creates a sugar gradient, where the sap with greater density (more like syrup!) naturally flows to the pour off valve. This configuration allows syrup to be drawn off at the pour off valve and sap to be added without lifting or emptying the pan. The continuous flow is more efficient and more fun than other DIY methods, which means more syrup and less work for you!

We hope you get many years of enjoyment from your *Seedling Evaporator*. Here's how to start!

Sourcing a 55-Gallon Barrel

Your kit contains everything you need to construct a backyard evaporator *except* for the 55-gallon barrel. Therefore, before you begin, you will need to find the 55-gallon barrel you will use to make your evaporator. Here are some guidelines. But remember, if you get stuck, there's always our *New 55-Gallon Steel Drum* available for separate purchase.

- The barrel **MUST** be both:
 - Closed head (meaning the top is not removeable,) **AND**
 - 55-gallon capacity
- The barrel **MAY** be:
 - Painted
 - Used
- You should **AVOID** barrels:
 - That have an interior lining,
 - That have been used to store something that is toxic or unknown.
- There is **NO NEED TO WORRY** about:
 - The number of bungs (holes in the ends) of the barrel,
 - The number or placement of ribs on your barrel
 - the gauge of metal the barrel is made of.

Building Your *Seedling Evaporator*

Step 1. Remove Paint from Barrel

Prepare your barrel for conversion by removing any paint from the outside of the barrel. We recommend you use a squirrel tail grinder attachment in a properly ventilated space, that you use personal eye, ear, and ventilation protection, and that you dispose of the paint properly in the trash.

Step 2. Transfer Template to Barrel

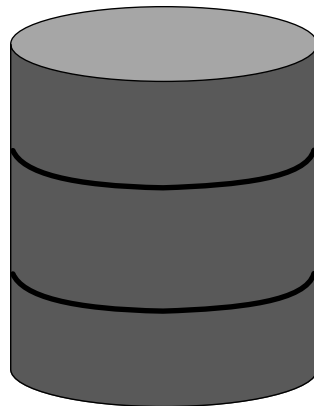

Stand the barrel on end on a flat and level surface, “door side” up.

Establish a flat and level surface and stand your barrel on end on the surface. The end of the barrel that you would like to have the door on (the front of the unit) should face upwards. If there

are bungs in your barrel, pay attention to where they are in relation to where the door will go. Where the bungs go are completely up to you! We like to have our bungs on the back side of the barrel, and to line them up vertically, but this is simply our preference.

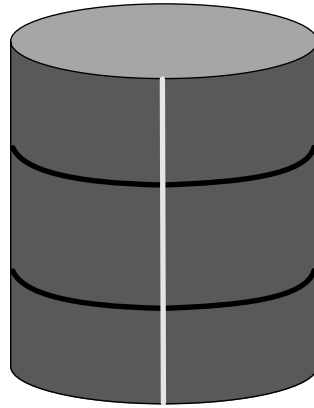

Draw a vertical line down one side of the barrel.

Using a level, plumb bob, drywall square, or the equivalent, establish and draw a vertical line that is perpendicular to the floor from the top of the barrel to the bottom of the barrel.

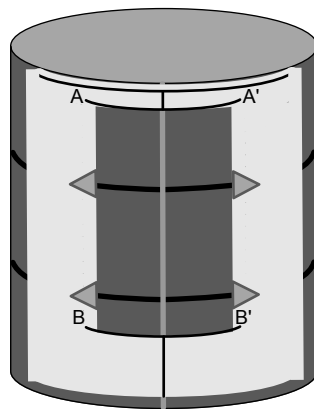

Cut out and align the template with the barrel and mark cutting lines.

Cut out the grey rectangle from the center of your template and align the center line marked on the template with the center line you just made on your barrel. Place the Front Line of the template along the top edge of your barrel. Cut out the grey triangles provided on the template and tape those along the ribs of your barrel so that one side of each triangle is aligned with the Side Cut Line and the opposite point of each triangle aligns with the peak of each rib. Number and placement of ribs varies depending on your barrel, so place your triangles on the ribs that your barrel has.

Mark the cutting lines on your barrel as indicated by the template. When marking, be sure to mark:

1. The entire End Line A-A'
2. The entire End Line B-B'
3. Both Side Cut Lines
4. The outside two sides of each small triangle

Step 3. Cut Barrel

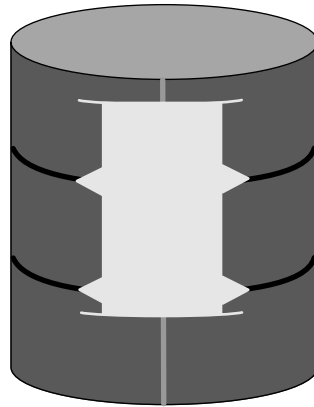

Cut the barrel along the cutting lines, making extra triangular cuts on each rib.

Cut the barrel along the cutting lines you've just made using a cutting wheel, a scroll saw, a reciprocating saw or the equivalent. Make sure you cut:

1. The entire End Line, A-A'
2. The entire End Line, B-B'
3. Both Side Cut Lines
4. The outside two sides of each small triangle

Step 4. Bend Barrel

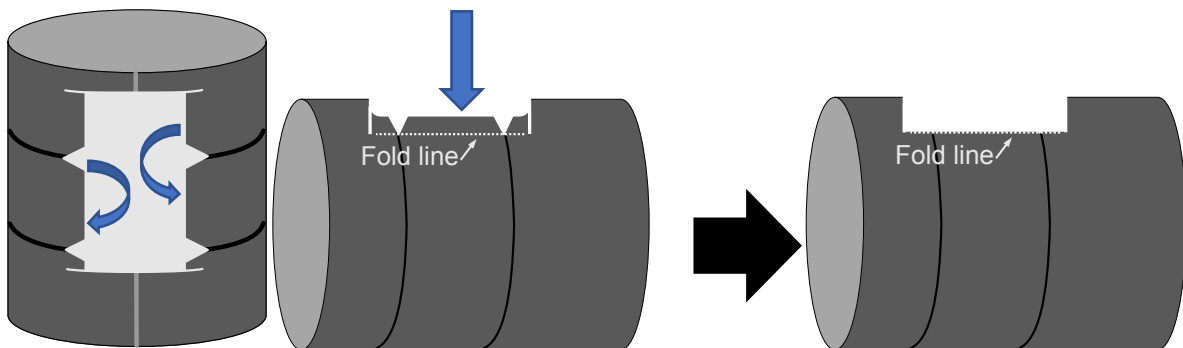

Bend flaps in the opening to create a flat, level surface for your pan.

Using a bender or plyers, bend the flaps the triangular cuts created in toward the interior of the barrel. These flaps will create a flat, level surface for your pan. When your barrel sits on legs, the flaps will be parallel to the floor, holding up your pan.

Step 5. Install Legs

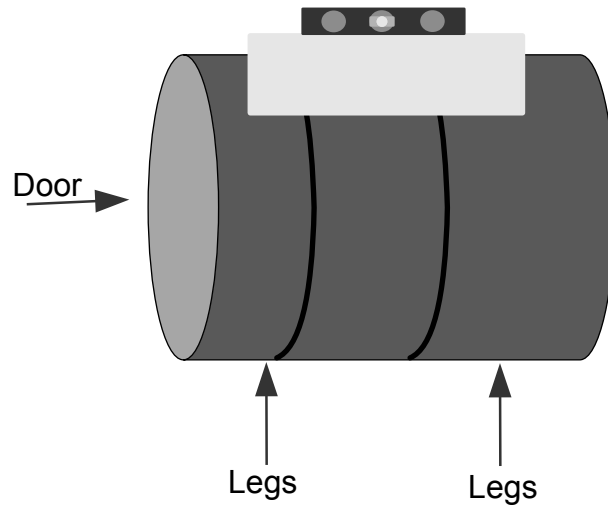

Dry fit the feet under the barrel and level the pan in the barrel opening.

Place the barrel on its side, with the pan opening faced up. Dry fit one set of legs under the front of the barrel, and one set closer to the back. The exact placement of the legs is up to you, as long as your pan is level at the end. Place the pan in the barrel opening and level it side-to-side and front-to-back, adjusting the bend in the barrel flaps supporting the pan accordingly.

When satisfied that your pan is level, mark the barrel where the drill holes will be for the legs. An easy way to do this is to take a permanent marker and insert the tip into the holes of the legs. Drill holes for the legs using a 5/16" bit appropriate for metal and install the legs using the hardware provided. If you have access to a center punch, we recommend using it to keep the drill from skipping around.

Step 6. Install Door

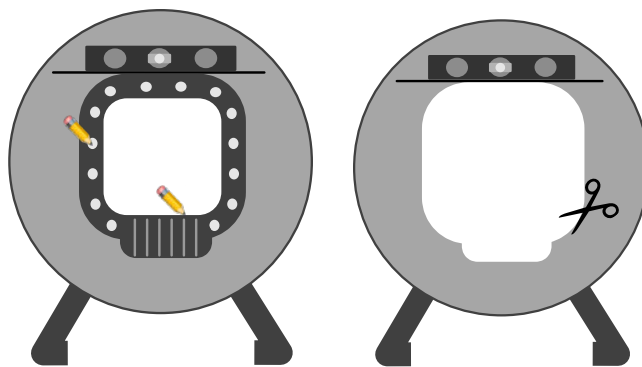

Place your unit on its feet on a level surface. Measure 16 inches up from the lowest part of the barrel lip. This will be the top edge of your door frame. Draw a level, horizontal line from the mark you just made.

Now set the unit on end with the back side of the barrel on the floor and the front, door side, facing up.

Use the level line to arrange the door. Remove the hinged portion of the door and roughly center the door frame side-to-side and mark the drilling holes for the door.

You also need to mark the portion of the barrel you will cut away for the door. You can do this by tracing the inside edge of the door frame. Be sure to also cut away the area beneath the door frame for the grate included in the door frame. This is so you can adjust the air flow while you are sugaring.

Cut away the door and grate hole and drill holes for the door with a 5/16" bit suitable for metal. Again, if you have access to a center punch, we recommend using it to keep the drill from skipping around. Install the door with the hardware provided.

Step 7. Install Flue

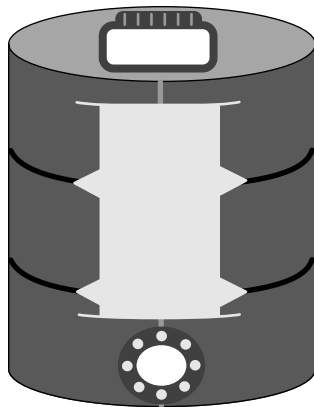

(Top view to show placement of flue pipe connection in relation to pan opening.)

Place the barrel back on its feet and place the flue pipe connector centered on the top of the drum, between the hole you cut for your pan and the back of your drum. Installing the Flue pipe connector will be easier if the damper is removed first. Mark the drilling holes for the flue pipe connector.

Drill holes for the flue pipe connector with a 5/16” bit suitable for metal. Again, if you have access to a center punch, we recommend using it to keep the drill from skipping around. Install the flue pipe connector with the hardware provided.

Install your damper (if you wish – it is not necessary for sugaring) and the flue pipe.

Step 8. Paint Firebox

Painting the barrel will protect your barrel from rust and wear. For best painting results, uninstall the feet, flue pipe and flue pipe connector and door, and paint the barrel with the flat black paint provided. Follow the safety precautions on the included high temp spray paint. One coat is sufficient and will leave you extra for future touchups. Let the paint dry and reinstall your unit.

Step 9. Installing Pan

Place the *Seedling Evaporator Pan* on the unit so that the draw-off is toward the front of the evaporator. Starting one thread back from the exit, wrap your bit of pipe tape around the draw-off to the right and wind around until completely used. Screw the ball valve on over the pipe tape.

Step 10. Sugar

Nice work! You built an evaporator. Here’s how to use your new unit.

Preparing To Sugar

Before you start, be smart! We’re talking about flame, hot metal and boiling syrup here, so:

- **DO NOT** operate while intoxicated or under the influence of alcohol or drugs.
- **DO NOT** heat your pan unless it has sap or other fluid in it. You can quickly destroy your pan by doing so.

Prepare the Unit

Put your *Seedling Evaporator* where you are going to sugar with it. If installed, remove the *Seedling Evaporator Pan*. Using shims and a two- or four-foot level, level your firebox front to back and side to side.

Place a layer of sand and/or ashes in the bottom of your barrel **CAUTION:** failure to place an insulating layer in the bottom of your barrel can result in catastrophic failure – the fire may burn right through your barrel!

Coat the exterior of the barrel with a thin layer of vegetable or olive oil (apply with a paper-towel or rag).

Clean and Check the Pan

Replace the pan. Using your level, confirm that your pan is level front to back and side to side.

Before you boil your first sap, you'll want to remove any residual materials from the pan. Here's how:

- Prepare a solution of 10 gallons of water combined with 2 tablespoons of baking soda. Fill the pan 2 or 3 inches deep with the solution.
- Start by building a small fire in the barrel and gradually build to a larger fire.
- Boil the solution for approximately 30 minutes, making sure the solution in the pan remains at approximately the 2-or 3-inch level by adding more solution, as needed.
- While boiling, check your equipment:
 - Check to see that there are no leaks at the fittings in the pan.
 - Assuming you have an even fire underneath, check to see that the pan is boiling evenly.
 - Open the valve – ensure it works and doesn't leak.
 - Check to see that your *Seedling Evaporator* is drafting and venting correctly (that the fire has adequate air intake, and that smoke is generally only coming out through the stack).
 - Allow the unit to cool and then drain the pan.
 - Rinse the pan thoroughly with clean water.

NOTE: It's always best to use non-chlorinated water if possible (chlorinated water can

eventually cause corrosion of the pan).

Operating your *Seedling Evaporator*

CAUTION: NEVER, EVER, EVER fire the *Seedling* up without liquid in the pan (or allow it to cool without liquid). Otherwise, the operation of the unit is relatively simple! Basically, you add sap at one location and it travels around the pan, becoming denser as it evaporates, until it gets to the valve. Here are the details:

1. Add 2 inches of sap in the pan. This is about 3 ½ gallons of sap.
2. Start your fire.
3. Get the sap boiling.
4. After the sap has boiled down to half of its volume, gradually add more sap at the back corner of the pan on the side that has the pour off valve. Continue to add sap at this location gradually as needed to keep the level at 2 inches. Do this for several hours.
5. There are a number of ways to tell if your syrup is “done.” The most sophisticated is to use an instrument called a syrup hydrometer to measure the sugar content of your boil. Another is to measure temperature: syrup boils at about 7 degrees F above the boiling point of water (so, approximately 219 degrees F). Therefore, when the temperature of the liquid close to the exit valve measures 219 degrees F, you can draw off syrup (this will take several hours). The syrup should have an amber color and have the consistency of . . . syrup.
6. Get a clean container and place it under the valve exit.
7. Open the valve and watch your exit temperature.
8. If possible, simultaneously add fresh sap at the introduction location. If not possible, add some before you draw off and some more after.
9. Continue to draw off syrup until your exit temperature drops below 219°. You will likely get less than a pint of finished syrup per draw.
10. You may also choose to draw off a bit early into another pot or pan and “finish” on, for example, a propane burner outside, or on the kitchen stove inside, where it may be easier to control and monitor the temperature. **Do not feel badly about choosing to go this route, especially at the beginning. Finishing over a wood fire requires practice and skill. You will get better at this every year!**

11. At the end of your boiling day, draw off about a gallon of the sap closest to being syrup. You can finish it as described above, or use it the next time you boil for a faster startup.
12. Monitor your evaporator until the boiling stops and the fire has died out.

Some Tips:

Don't add too much new sap at one time, and try to maintain a constant boil. This will result in a more efficient process and lighter syrup.

To obtain high, even heat, use dry, mixed (hardwoods and softwoods) wood that is thinly split (like the thickest part of a baseball bat).

Load often with small amounts of wood to maintain a consistent level of heat.

Maintaining your *Seedling Evaporator*

Your *Seedling* should have a long life. Just how long (And how beautiful a life it is) will depend on how you care for it.

During Sugaring Season

Clean out some, but not all, of the ashes when the unit has cooled after each boil.

After the Season is Over

Your pan will likely have some deposits/scaling. To clean, use as much of the baking soda-water solution described above as you need to so that the coating to be removed is covered with water. Simmer the solution for a minimum of one hour and ideally until you see the deposits dissolve. Let the fire die out and leave the pan overnight. Brush off the loose scale and rinse the pan. If deposits remain, you may want to repeat the process. Store your pan in an indoor location (a garage, shed or barn is fine).

The best practice is to clean out the ash and oil the inside of your barrel with vegetable or olive oil when not in use for extended periods of time, and, unless your *Seedling Evaporator* can be stored in a garage or barn, you should cover it when not in use. If water gets in your barrel, be sure to dump it out, dry it out, and apply another layer of oil to discourage rust.

Expansion and contraction caused by heating, cooling and exposure to the elements may eventually cause some cracking, flaking, or thinning in the paint on your *Seedling Evaporator*. If you notice this, after the barrel has cooled, sand the area with 100 grit sandpaper and repaint with *Sapling Flat Black Paint*, or the equivalent.